

\* MAXIMUM TURNING SPACE SLOPE IS 2% IN EACH DIRECTION OF TRAVEL. MINIMUM DIMENSIONS 5' x 5'. SEE NOTES.

\*\* MAXIMUM RAMP CROSS SLOPE IS 2.0%, RUNNING SLOPE 5% - 7% (8.3% MAXIMUM). SEE NOTES.

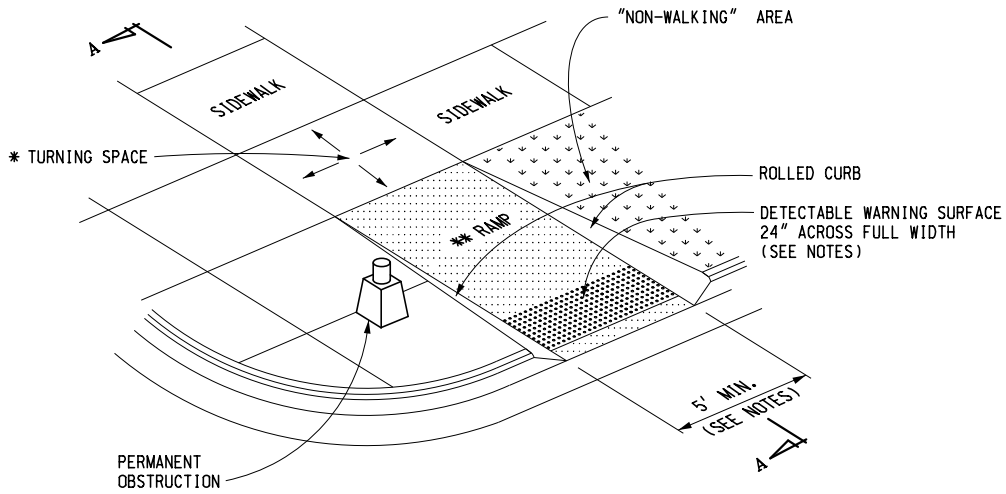

**SIDEWALK RAMP TYPE R**  
(ROLLED SIDES)

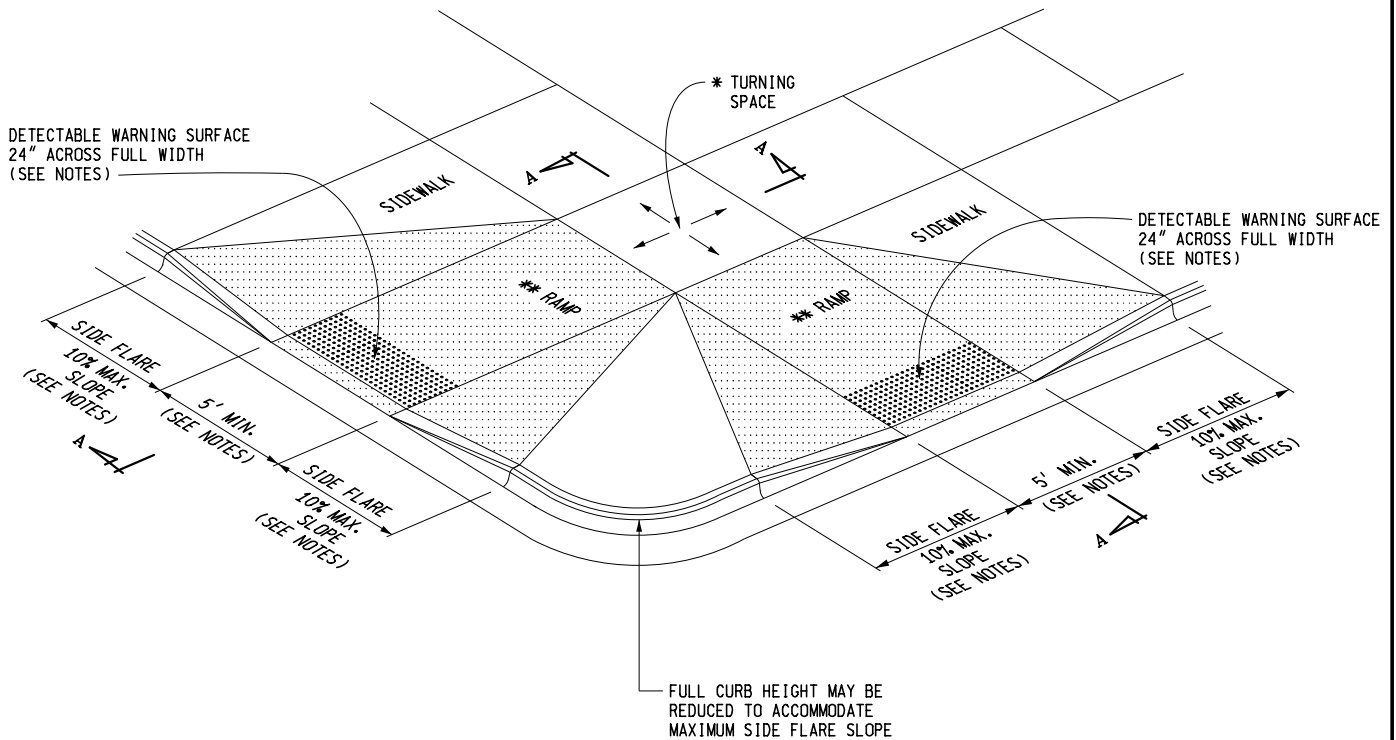

**SIDEWALK RAMP TYPE F**  
(FLARED SIDES, TWO RAMPS SHOWN)



PREPARED BY  
DESIGN DIVISION

DRAWN BY: B.L.T.

CHECKED BY: W.K.P.

DEPARTMENT DIRECTOR  
Kirk T. Stuedle

APPROVED BY: *Randy V. Puffel*  
DIRECTOR, BUREAU OF FIELD SERVICES

APPROVED BY: *Mark A. Van Park*  
DIRECTOR, BUREAU OF HIGHWAY DEVELOPMENT

MICHIGAN DEPARTMENT OF TRANSPORTATION  
BUREAU OF HIGHWAY DEVELOPMENT STANDARD PLAN FOR

**SIDEWALK RAMP AND  
DETECTABLE WARNING DETAILS**

1-25-2013  
F.H.W.A. APPROVAL

10-3-2012  
PLAN DATE

**R-28-H**

SHEET  
1 OF 7

\* MAXIMUM TURNING SPACE SLOPE IS 2% IN EACH DIRECTION OF TRAVEL. MINIMUM DIMENSIONS 5' x 5'. SEE NOTES.

\*\* MAXIMUM RAMP CROSS SLOPE IS 2.0%, RUNNING SLOPE 5% - 7% (8.3% MAXIMUM). SEE NOTES.

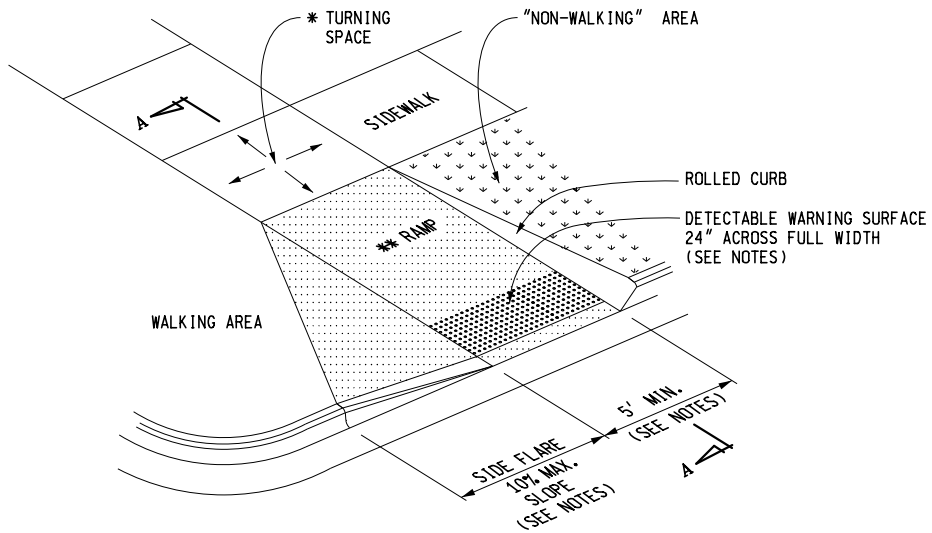

**SIDEWALK RAMP TYPE RF**  
(ROLLED / FLARED SIDES)

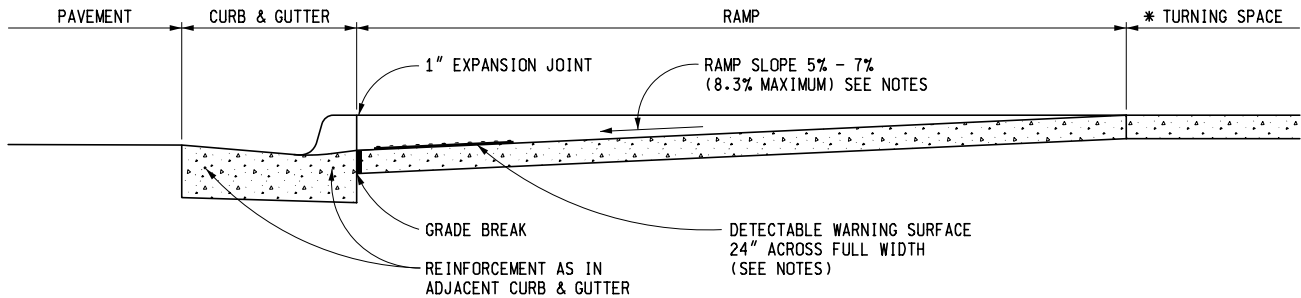

**SECTION A-A**

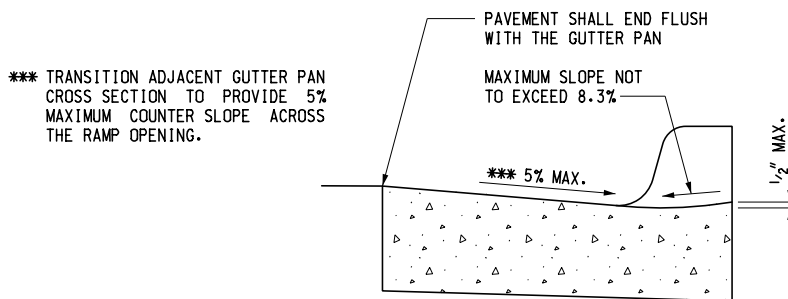

**SECTION THROUGH CURB CUT**  
(TYPICAL ALL RAMP TYPES)

MICHIGAN DEPARTMENT OF TRANSPORTATION  
BUREAU OF HIGHWAY DEVELOPMENT STANDARD PLAN FOR

**SIDEWALK RAMP AND  
DETECTABLE WARNING DETAILS**

1-25-2013  
F.H.W.A. APPROVAL

10-3-2012  
PLAN DATE

**R-28-H**

SHEET  
2 OF 7

\* MAXIMUM TURNING SPACE SLOPE IS 2% IN EACH DIRECTION OF TRAVEL. MINIMUM DIMENSIONS 5' x 5'. SEE NOTES.

\*\* MAXIMUM RAMP CROSS SLOPE IS 2.0%, RUNNING SLOPE 5% - 7% (8.3% MAXIMUM). SEE NOTES.

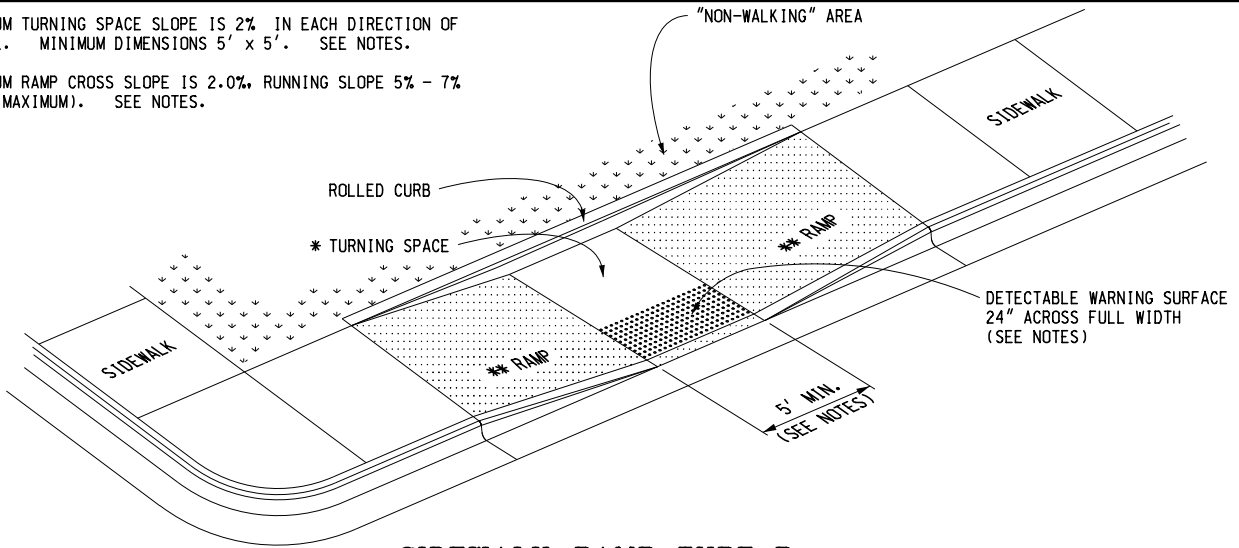

**SIDEWALK RAMP TYPE P**

(PARALLEL RAMP)

DO NOT USE IN AREAS WHERE PONDING MAY OCCUR

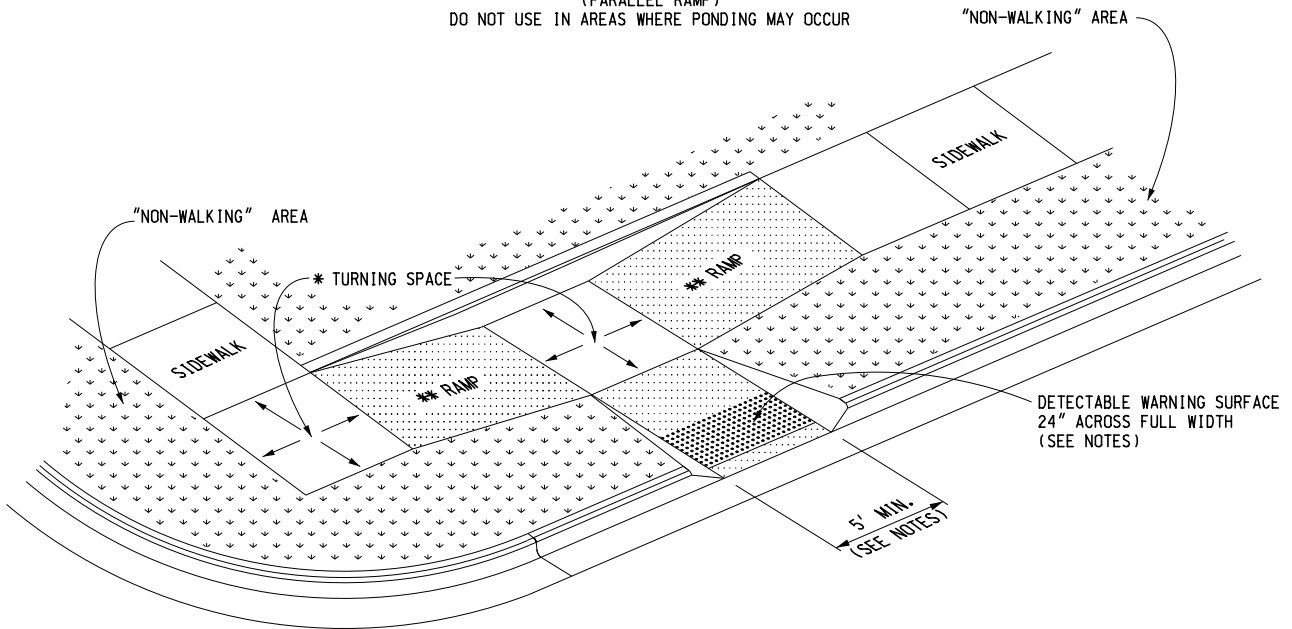

**SIDEWALK RAMP TYPE C**

(COMBINATION RAMP)

USE 24" DEEP DETECTABLE WARNINGS IF MEDIAN WIDTH IS AT LEAST 6'-0". OTHERWISE NO DETECTABLE WARNING IS REQUIRED.

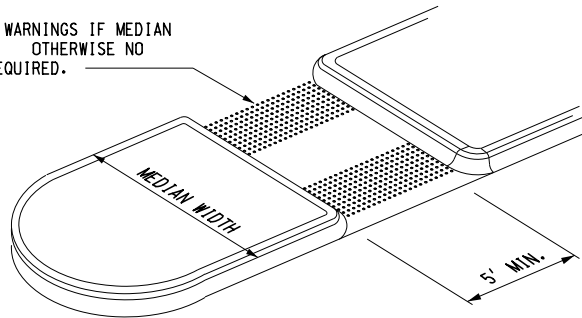

**SIDEWALK RAMP TYPE M**

(MEDIAN ISLAND)

MICHIGAN DEPARTMENT OF TRANSPORTATION  
BUREAU OF HIGHWAY DEVELOPMENT STANDARD PLAN FOR

**SIDEWALK RAMP AND  
DETECTABLE WARNING DETAILS**

1-25-2013  
F.H.W.A. APPROVAL

10-3-2012  
PLAN DATE

**R-28-H**

SHEET  
3 OF 7

\* MAXIMUM TURNING SPACE SLOPE IS 2% IN EACH DIRECTION OF TRAVEL. MINIMUM DIMENSIONS 5' x 5'. SEE NOTES.

\*\* MAXIMUM RAMP CROSS SLOPE IS 2.0%, RUNNING SLOPE 5% - 7% (8.3% MAXIMUM). SEE NOTES.

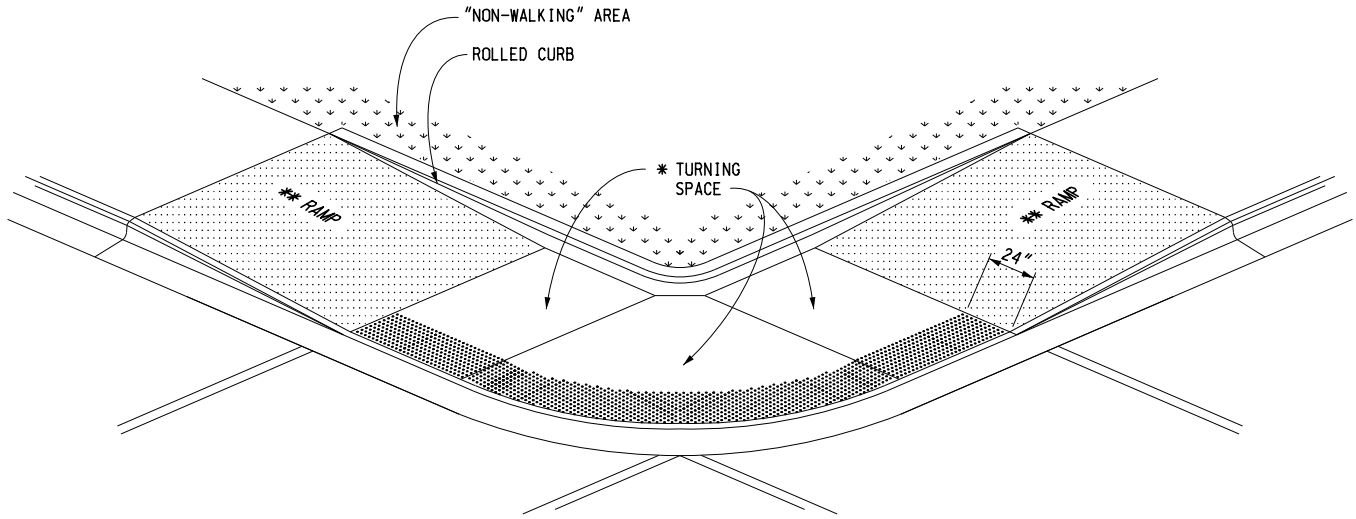

( RADIAL DETECTABLE WARNING SHOWN )

DETECTABLE WARNING SURFACE COVERAGE IS 24" FOR THE FULL WIDTH OF THE RAMP OPENING EXCLUDING CURBED OR CURB TRANSITION AREAS. A CURB OFFSET NOT GREATER THAN 2" MEASURED ALONG THE EDGES OF THE DETECTABLE WARNING IS ALLOWABLE.

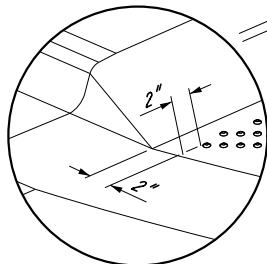
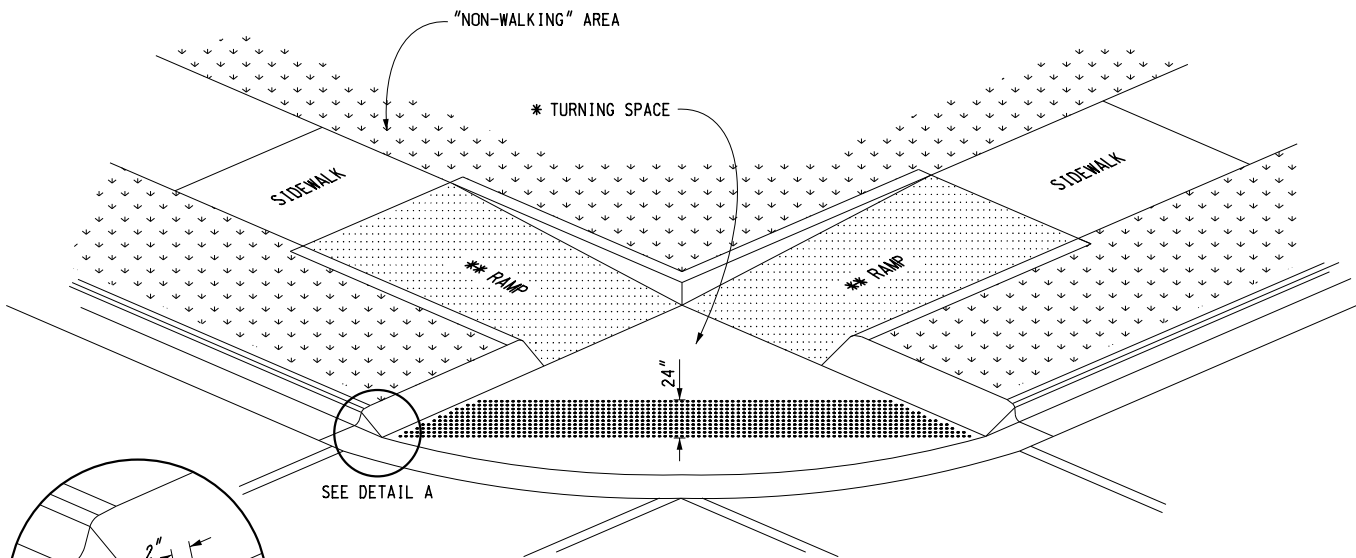

DETAIL A

( TANGENT DETECTABLE WARNING SHOWN )

A CONCRETE BORDER OFFSET NOT GREATER THAN 2" IS ALLOWABLE FOR DETECTABLE WARNING INSTALLATION WHERE THE BACK OF CURB IS ON A RADIUS, THE BORDER OFFSET MAY BE MEASURED FROM THE END OF THE RADIUS.

### SIDEWALK RAMP TYPE D

( DEPRESSED CORNER )

USE ONLY WHEN INDEPENDENT DIRECTIONAL RAMPS CAN NOT BE CONSTRUCTED FOR EACH CROSSING DIRECTION

MICHIGAN DEPARTMENT OF TRANSPORTATION  
BUREAU OF HIGHWAY DEVELOPMENT STANDARD PLAN FOR

## SIDEWALK RAMP AND DETECTABLE WARNING DETAILS

1-25-2013  
F.H.W.A. APPROVAL

10-3-2012  
PLAN DATE

R-28-H

SHEET  
4 OF 7

\* THE DETECTABLE WARNING SURFACE SHALL BE LOCATED SO THAT THE EDGE NEAREST THE RAIL CROSSING IS 6' MINIMUM AND 15' MAXIMUM FROM THE CENTERLINE OF THE NEAREST RAIL. DO NOT PLACE DETECTABLE WARNING ON RAILROAD CROSSING MATERIAL.

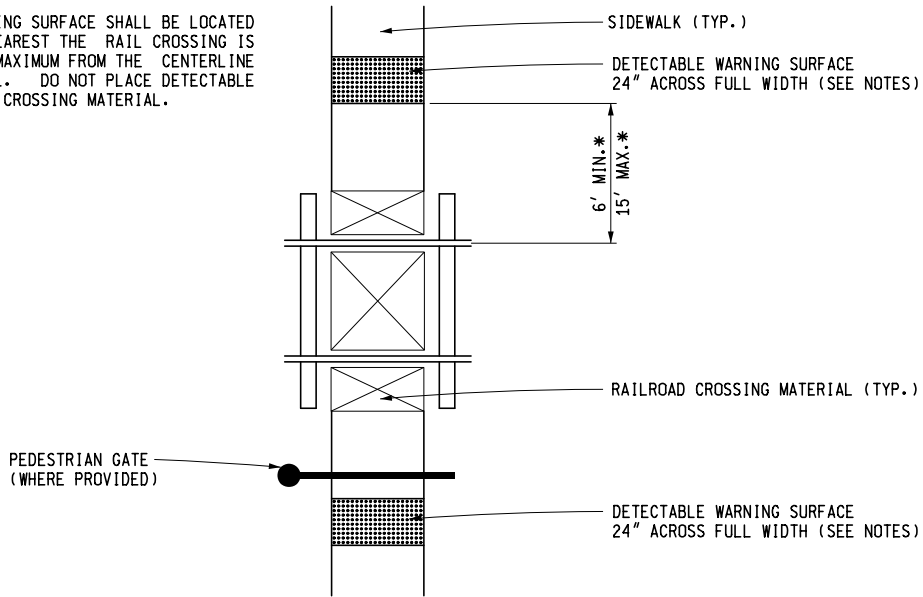

**DETECTABLE WARNING AT RAILROAD CROSSING**

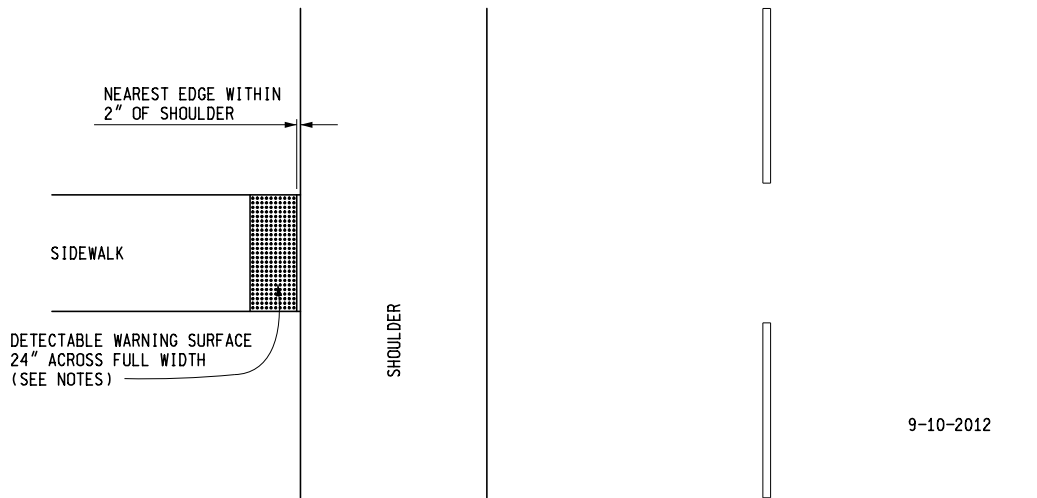





**DETECTABLE WARNING AT FLUSH SHOULDER OR ROADWAY**

MICHIGAN DEPARTMENT OF TRANSPORTATION  
 BUREAU OF HIGHWAY DEVELOPMENT STANDARD PLAN FOR

**SIDEWALK RAMP AND  
 DETECTABLE WARNING DETAILS**

1-25-2013 F.H.W.A. APPROVAL	10-3-2012 PLAN DATE	<b>R-28-H</b>	SHEET 5 OF 7
--------------------------------	------------------------	---------------	-----------------

**LEGEND**

	SIDEWALK RAMP
	"NON-WALKING" AREA
	CROSSWALK MARKING
	PREFERRED LOCATION OF DRAINAGE INLET (TYP.)
	ALTERNATE LOCATION OF DRAINAGE INLET (TYP.)

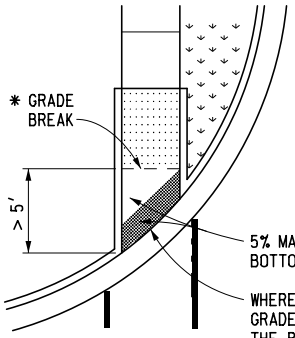

\* GRADE BREAK  
 > 5'  
 5% MAX. SLOPE BEYOND BOTTOM GRADE BREAK  
 WHERE EITHER END OF THE BOTTOM GRADE BREAK IS MORE THAN 5' FROM THE BACK OF CURB, THE DETECTABLE WARNING SHALL BE LOCATED ON THE LOWER LANDING. (DOME ORIENTATION IS NOT SIGNIFICANT ON RADIUS)

SIDEWALK RAMP LOCATED IN RADIUS (TYPE R SHOWN)  
 (GRADE BREAK GREATER THAN 5')

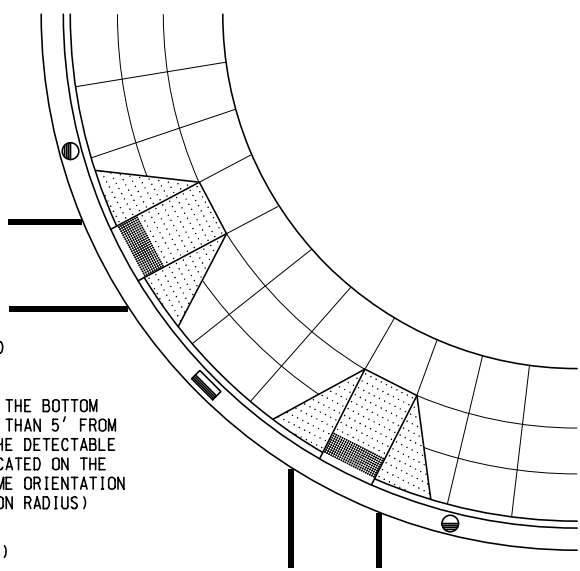

SIDEWALK RAMP PERPENDICULAR TO RADIAL CURB (TYPE F SHOWN)  
 (USE WITH RADIAL CURB WHEN THE CROSSWALK AND SIDEWALK RAMP ARE NOT ALIGNED)

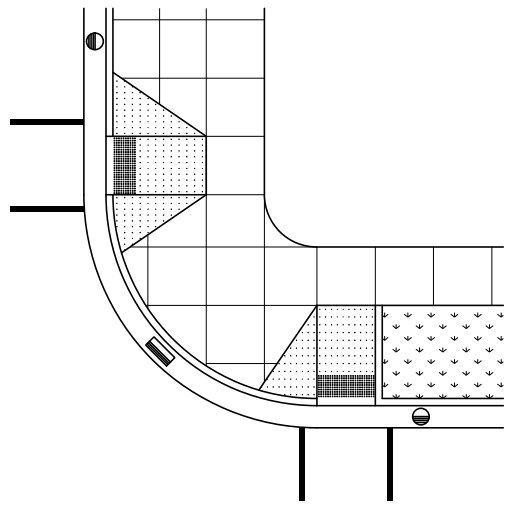

SIDEWALK RAMP PERPENDICULAR TO TANGENT CURB  
 (TYPE F AND TYPE RF SHOWN)

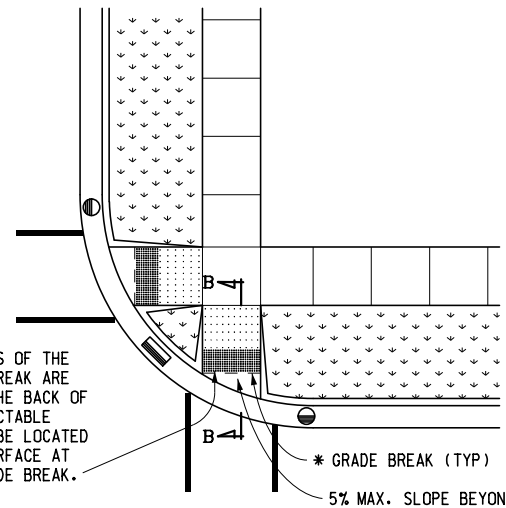

WHERE BOTH ENDS OF THE BOTTOM GRADE BREAK ARE WITHIN 5' OF THE BACK OF CURB, THE DETECTABLE WARNING SHALL BE LOCATED ON THE RAMP SURFACE AT THE BOTTOM GRADE BREAK.  
 \* GRADE BREAK (TYP.)  
 5% MAX. SLOPE BEYOND BOTTOM GRADE BREAK

SIDEWALK RAMP LOCATED IN RADIUS (TYPE R SHOWN)  
 (GRADE BREAK LESS THAN 5')

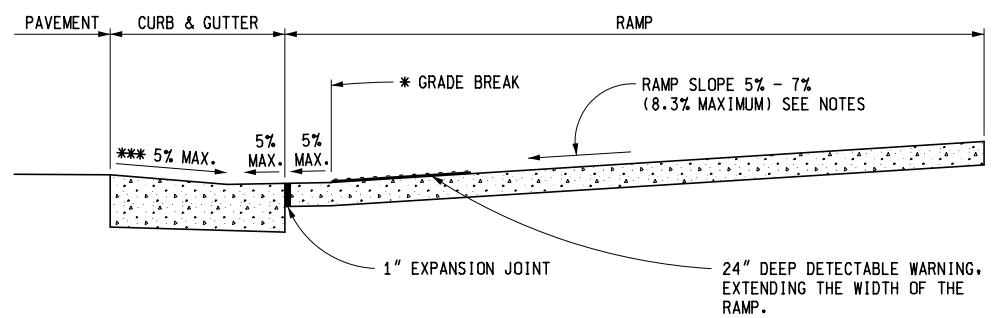

\* GRADE BREAKS AT THE TOP AND BOTTOM OF CURB RAMPS SHALL BE PERPENDICULAR TO THE DIRECTION OF TRAVEL.

\*\*\* TRANSITION ADJACENT GUTTER PAN CROSS SECTION TO PROVIDE 5% MAXIMUM COUNTER SLOPE ACROSS THE RAMP OPENING.

**SECTION B-B  
 SIDEWALK RAMP ORIENTATION**

MICHIGAN DEPARTMENT OF TRANSPORTATION  
 BUREAU OF HIGHWAY DEVELOPMENT STANDARD PLAN FOR

**SIDEWALK RAMP AND  
 DETECTABLE WARNING DETAILS**

1-25-2013 F.H.W.A. APPROVAL	10-3-2012 PLAN DATE	<b>R-28-H</b>	SHEET 6 OF 7
--------------------------------	------------------------	---------------	-----------------

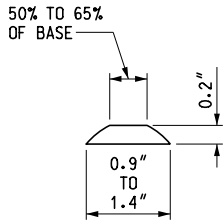

**DOMES SECTION**

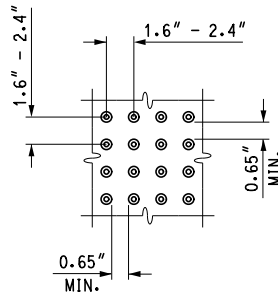

**DOMES SPACING**

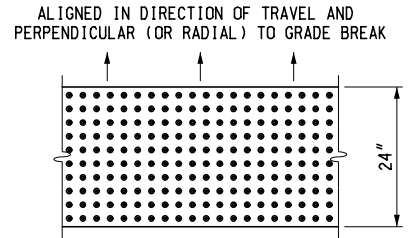

**DOMES ALIGNMENT**

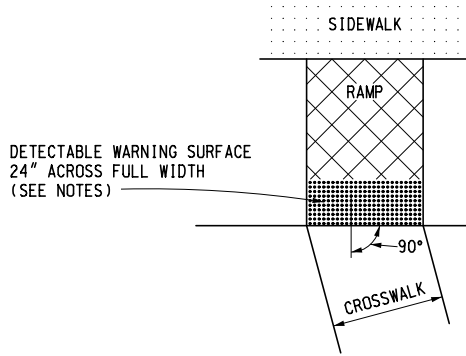

**DETECTABLE WARNING DETAILS**

**NOTES:**

DETAILS SPECIFIED ON THIS PLAN APPLY TO ALL CONSTRUCTION, RECONSTRUCTION, OR ALTERATION OF STREETS, CURBS, OR SIDEWALKS BY ALL PUBLIC AGENCIES AND BY ALL PRIVATE ORGANIZATIONS CONSTRUCTING FACILITIES FOR PUBLIC USE.

SIDEWALK RAMPS ARE TO BE LOCATED AS SPECIFIED ON THE PLANS OR AS DIRECTED BY THE ENGINEER.

RAMPS SHALL BE PROVIDED AT ALL CORNERS OF AN INTERSECTION WHERE THERE IS EXISTING OR PROPOSED SIDEWALK AND CURB. RAMPS SHALL ALSO BE PROVIDED AT MARKED AND/OR SIGNALIZED MID-BLOCK CROSSINGS.

SURFACE TEXTURE OF THE RAMP SHALL BE THAT OBTAINED BY A COARSE BROOMING, TRANSVERSE TO THE RUNNING SLOPE.

SIDEWALK SHALL BE RAMPED WHERE THE DRIVEWAY CURB IS EXTENDED ACROSS THE WALK.

CARE SHALL BE TAKEN TO ASSURE A UNIFORM GRADE ON THE RAMP. WHERE CONDITIONS PERMIT, IT IS DESIRABLE THAT THE SLOPE OF THE RAMP BE IN ONLY ONE DIRECTION, PARALLEL TO THE DIRECTION OF TRAVEL.

RAMP WIDTH SHALL BE INCREASED, IF NECESSARY, TO ACCOMMODATE SIDEWALK SNOW REMOVAL EQUIPMENT NORMALLY USED BY THE MUNICIPALITY.

PROVIDE TURNING SPACES WHERE PEDESTRIAN TURNING MOVEMENTS ARE REQUIRED.

WHEN 5' MINIMUM WIDTHS ARE NOT FEASIBLE, RAMP WIDTH MAY BE REDUCED TO NOT LESS THAN 4' AND TURNING SPACES TO NOT LESS THAN 4' x 4'.

DETECTABLE WARNING SURFACE COVERAGE IS 24" MINIMUM IN THE DIRECTION OF RAMP/PATH TRAVEL AND THE FULL WIDTH OF THE RAMP/PATH OPENING EXCLUDING CURBED OR FLARED CURB TRANSITION AREAS. A CURB OFFSET NOT GREATER THAN 2" MEASURED ALONG THE EDGES OF THE DETECTABLE WARNING (OR AS OTHERWISE SHOWN ON THIS STANDARD) IS ALLOWABLE.

FOR NEW ROADWAY CONSTRUCTION, THE RAMP CROSS SLOPE MAY NOT EXCEED 2%. FOR ALTERATIONS TO EXISTING ROADWAYS, THE CROSS SLOPE MAY BE TRANSITIONED TO MEET AN EXISTING ROADWAY GRADE. THE CROSS SLOPE TRANSITION SHALL BE APPLIED UNIFORMLY OVER THE FULL LENGTH OF THE RAMP.

THE MAXIMUM RUNNING SLOPE OF 8.3% IS RELATIVE TO A FLAT (0%) REFERENCE. HOWEVER, IT SHALL NOT REQUIRE ANY RAMP OR SERIES OF RAMPS TO EXCEED 15 FEET IN LENGTH.

DRAINAGE STRUCTURES SHOULD NOT BE PLACED IN LINE WITH RAMPS. THE LOCATION OF THE DRAINAGE STRUCTURE SHOULD TAKE PRECEDENCE OVER THE LOCATION OF THE RAMP. WHERE EXISTING DRAINAGE STRUCTURES ARE LOCATED IN THE RAMP PATH OF TRAVEL, USE A MANUFACTURER'S ADA COMPLIANT GRATE. OPENINGS SHALL NOT BE GREATER THAN 1/2". ELONGATED OPENINGS SHALL BE PLACED SO THAT THE LONG DIMENSION IS PERPENDICULAR TO THE DOMINANT DIRECTION OF TRAVEL.

TRANSITION THE GUTTER PAN CROSS SECTION SUCH THAT THE COUNTER SLOPE IN THE DIRECTION OF RAMP TRAVEL IS NOT GREATER THAN 5%. MAINTAIN THE NORMAL GUTTER PAN CROSS SECTION ACROSS DRAINAGE STRUCTURES.

THE TOP OF THE JOINT FILLER FOR ALL RAMP TYPES SHALL BE FLUSH WITH THE ADJACENT CONCRETE.

CROSSWALK AND STOP LINE MARKINGS, IF USED, SHALL BE SO LOCATED AS TO STOP TRAFFIC SHORT OF RAMP CROSSINGS. SPECIFIC DETAILS FOR MARKING APPLICATIONS ARE GIVEN IN THE "MICHIGAN MANUAL OF UNIFORM TRAFFIC CONTROL DEVICES".

FLARED SIDES WITH A SLOPE OF 10% MAXIMUM, MEASURED ALONG THE ROADSIDE CURB LINE, SHALL BE PROVIDED WHERE AN UNOBSTRUCTED CIRCULATION PATH LATERALLY CROSSES THE SIDEWALK RAMP. FLARED SIDES ARE NOT REQUIRED WHERE THE RAMP IS BORDERED BY LANDSCAPING, UNPAVED SURFACE OR PERMANENT FIXED OBJECTS. WHERE THEY ARE NOT REQUIRED, FLARED SIDES CAN BE CONSIDERED IN ORDER TO AVOID SHARP CURB RETURNS AT RAMP OPENINGS.

DETECTABLE WARNING PLATES MUST BE INSTALLED USING FABRICATED OR FIELD CUT UNITS CAST AND/OR ANCHORED IN THE PAVEMENT TO RESIST SHIFTING OR HEAVING.

MICHIGAN DEPARTMENT OF TRANSPORTATION  
BUREAU OF HIGHWAY DEVELOPMENT STANDARD PLAN FOR

**SIDEWALK RAMP AND  
DETECTABLE WARNING DETAILS**

1-25-2013 F.H.W.A. APPROVAL	10-3-2012 PLAN DATE	<b>R-28-H</b>	SHEET 7 OF 7
--------------------------------	------------------------	---------------	-----------------